

REV.	ECN NO.	DESCRIPTION	DESIGN	DATE
A		INITIAL	Kai	2018.03.29

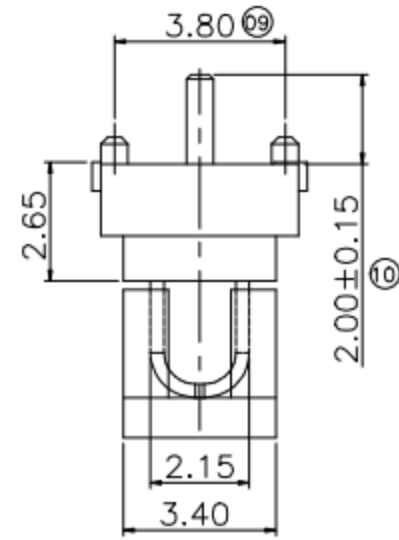

DIM.A	DIM.B	DIM.C
6.50	5.90	4.00
8.50	7.90	6.00
10.50	9.90	8.00
12.50	11.90	10.00
14.50	13.90	12.00
16.50	15.90	14.00
18.50	17.90	16.00
20.50	19.90	18.00

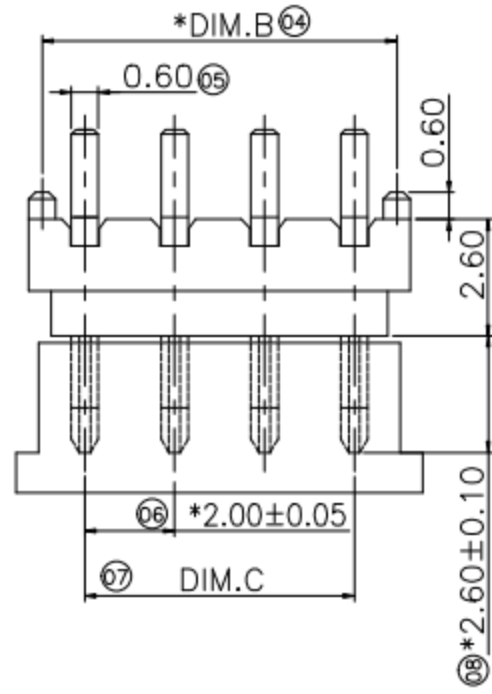
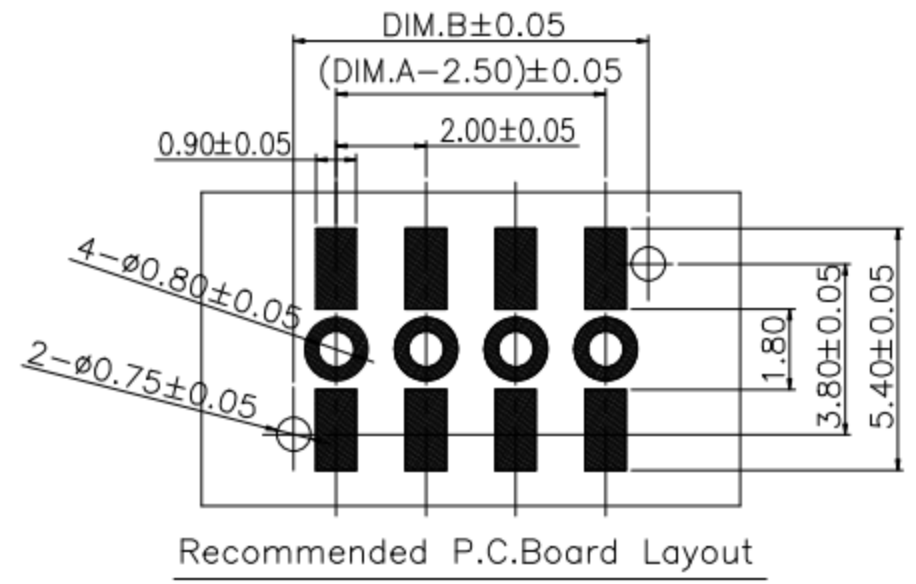
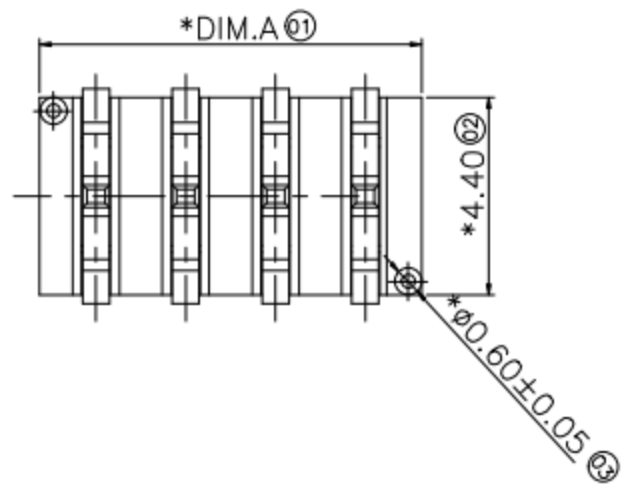

NOTE:
 Material
 Insulator:Nylon 9T(UL94V-0)
 Contact:phosphor Bronze
 Contact Plated:Gold over Nickel or Tin
 Specification
 Rated voltage: 12V 30V
 Current rating: 3A 5A
 instant CURRENT:7A
 Contact Resistance:30MΩ
 Insulation Resistance:100MΩ
 Dielectric Voltage:1000V
 Operdting Temperature:-40°~105°

ITEM	PART NAME	Q'TY	MATERTAL	DESCRIPTION	REMARK
②	HOUSING	1	LCP		BLACK
①	CONTACT A	2	PHOSPHOR BRONZE 0.20T	Au PLATED	

UNLESS OTHERWISE SPECIFIED TOLERANCES

DECIMALS:		ANGLES:	
DIM	TOL	DIM	TOL
X.	±0.50	X.	±2'
X.X	±0.30	X.X	±1'
X.XX	±0.20	X.XX	
X.XXX	±0.10	X.XXX	

东莞市高迪电子有限公司

DWG NO.	PART NAME:
DESIGN:	PART NO.
CHECK:	REV. A
APPROVED	UNIT: mm
	SHEET: 1/1